



# Standard Commercial Whiteboard

Our Standard Commercial Whiteboard is a versatile and durable solution for a wide range of light to medium uses. Its galvanised steel backing and low-density fibreboard core make it a hard-wearing magnetic surface, giving it its commercial quality. The anodised aluminium frame features moulded corner fixings for easy installation and removable caps to conceal the mounting screws.

## FEATURES

- Hard-Wearing Magnetic Surface
- Galvanised Steel Backing
- Low Density Fiberboard Core
- Dry-Erase Board
- Anodised Aluminium Frame
- Flexible Mounting System
- Aluminium Pen Tray Included
- Custom Sizes Available
- Manufactured in Brisbane
- 8 Year Warranty

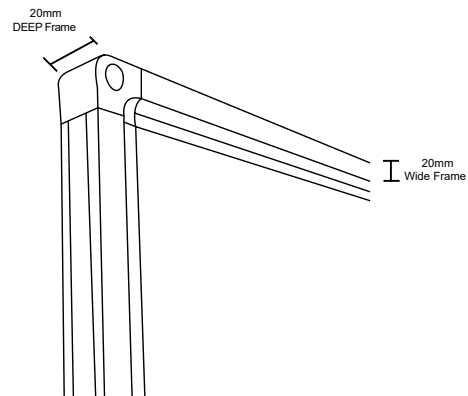

## DIMENSIONS

600 x 450 | 900 x 600 | 900 x 900 | 1200 x 900 | 1200 x 1200 | 1500 x 900 | 1500 x 1200 | 1800 x 900 | 1800 x 1200 | 2100 x 1200 | 2400 x 1200 | 3000 x 1200 | 3600 x 1200

For Orders Please Contact

PH: 1300 849 152

[sales@whiteboardsandpinboards.com.au](mailto:sales@whiteboardsandpinboards.com.au)