



Because it matters



Headquarters BenQ Corporation	Asia Pacific BenQ Asia Pacific Corp.	China BenQ (IT) Co., Ltd.	North America BenQ America Corp.	Europe BenQ Europe B.V.	Latin and Central America BenQ Latin America Corp.
16 Jihu Road, Neihu, Taipei 114, Taiwan Tel : +886-2-2727-8899 Fax : +886-2-2656-2438	12 Jihu Road, Neihu, Taipei 114, Taiwan Tel : +886-2-2727-8899 Fax : +886-2-2656-2438	181 Zhuyuan Road, Suzhou New District, Suzhou, China Tel : +86-512-6807-8800 Fax : +86-512-6809-7010	3200 Park Center Drive, Suite 150 Costa Mesa, CA 92626 U.S.A Tel : +1-714-559-4900 Fax : +1-714-557-0200	Meerenakkerweg 1-17, 5652 AR Eindhoven, The Netherlands Tel : +31(0) 88-888-9200 Fax : +31(0) 88-888-9299	8200 N.W. 33 Street, Suite 301 Miami, FL 33122 U.S.A. Tel : +1-305-421 1200 Fax : +1-305-421 1201

© 2019 BenQ Corp. Specification may vary by region, please visit your local stores for details. Actual product's features and specifications are subject to change without notice.

This material may include corporate names and trademarks of third parties which are the properties of the third parties respectively.

Doc: DSP_CP6501K/CP8601K_DS_EN_201908

BenQ DuoBoard

A Duo Creates Infinite Possibilities



Because it matters

DuoBoard Corporate Interactive Flat Panel

BenQ DuoBoard is designed to tap into the dynamic possibilities of the modern meeting room and help businesses develop and maintain an environment where ideas flow freely. It allows for extended, seamless team collaboration, stimulating more innovative ideas and is perfect for fostering collaboration then turning your creativities from abstract to real. BenQ DuoBoard is the beginning of infinite possibilities.

Set up Your Meeting by One-Step

Instant Meetings without Wait

DuoBoard allows users to just bring their own portable devices to start the meeting right away. The built-in camera and array mic also allow for direct video conference without troublesome preparations and cable cluster. By supporting various input sources including OPS, HDMI, VGA, USB flash drive and more, DuoBoard offers an excellent compatibility.



Account Management System for Personalized Workspace

DuoBoard supports multi-account management through NFC technology, which allows users directly access and manage their personal system-setting, network drive and cloud storage space such as Google drive and Dropbox, by simply scanning BenQ designed NFC cards without having to enter password.



Start Meetings Quickly with BenQ Launcher

DuoBoard makes it easy for users to launch meetings without delay. Created to aggregate all key tools in one hub, BenQ Launcher allows employees to access video input sources or use the EZWrite whiteboard without having to log into their accounts. Additionally, BenQ Launcher comes with a task switcher, letting users switch between recent apps and input signal sources with just a simple touch.



Video Conferences Anytime, Anywhere

DuoBoard is pre-loaded with useful business apps such as Blizz by TeamViewer, a powerful cloud meeting service that unifies video conferencing, simple online meetings, group messaging, and discussion management. With a one-click-to-start interface, you can easily host a high-quality audiovisual group meeting by connecting various devices. The embedded camera and array mic enhance meeting efficiency, boosting productivity.



- 1 Rich I/O Port
- 2 OPS Slot
- 3 Array Mic x 6 & Camera
- 4 4K Resolution Panel
- 5 Capacitive Touch Technology Direct Bonding
- 6 Germ-Resistant Screen
- 7 Air Quality Sensor & Light Sensor
- 8 Motion Sensor
- 9 NFC Sensor
- 10 Active Pen



Flexible Anytime Annotation



Annotate and Collaborate Everywhere with the Cloud

Boasting powerful cloud features, EZWrite 5 streamlines discussions by letting employees share notes and ideas whether they are in the office, at home, or on a business trip. With BenQ's exclusive AMS service, employees can save materials in the cloud and access them directly from the BenQ IFP, without need for a laptop or smart device.



Sticky Notes

Packed with user-friendly features, EZWrite 5 is the leading annotation solution for boosting collaboration and communication during meetings. With the EZWrite Cloud Whiteboard, employees can collect, categorize, edit, and share notes between the IFP and their mobile devices or laptops, ensuring they'll have access to their important materials everywhere.

Collaboration+ Unleashes Infinite Possibilities



Duo Boards

This feature is designed for extending collaboration, fostering teamwork, and stimulating innovation. Combining two DuoBoards together, users can seamlessly double the collaboration space and develop borderless ideas. Users can use the EZwrite to work jointly with their teammates to complete a complicated task. Files saved in individual IFP are also shareable between IFPs. One plus one is definitely more than two.



Duo Windows

This feature allows users to work on two tasks at the same time, on a single IFP, doubling efficiency. Users are now able to open two applications simultaneously and complete multi-tasks quicker than ever before. Scenarios include: comparing two documents, writing meeting minutes during a videoconference, searching for information while brainstorming, opening an Android app with other input source data, and much more.



Duo OS

Duo OS achieves cross-platform compatibility between Android, iOS, macOS, and Windows OS. This allows users to capture a picture file from their own device, edit it with EZWrite, and then save to the IFP, cloud storage, or the original device for further use. Duo OS allows for easy switches between various operating systems for more collaboration.

Adjustable Screen Capture Regions and Easy Import

With EZWrite's Floating Tool, users can capture screen shots of anything on screen, regardless of the source, including content from apps, websites, and videos. They can then import this content into EZWrite 5 for further discussion and annotation on a brand new page.

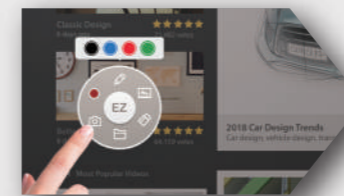

Step 1. Press the Screen Shot button on the Floating Tool



Step 2. Capture on-screen content directly on the IFP



Step 3. Import to EZWrite 5 and make annotations



Dual Pens for Simultaneous Collaboration

EZWrite 5 comes with dual pens that allow two users to write or draw simultaneously with different colors, making it ideal for multiple presenters.



Floating Tool

EZWrite's built-in Floating Tool empowers employees to write on top of any app, video, website, document, or image. Whether using Windows, Mac, Chrome, or Android™, users can take notes on top of any on-screen content and save them for later use. Screen capture lets users capture all of the screen or just a part that they select with their fingers.



Intelligent Handwriting Recognition

EZWrite's handwriting recognition feature allows users to instantly convert written text, numbers, forms, and drawings into easily legible digital text without having to switch modes.

InstaShare Wireless Solution for Seamless Collaboration

4 Split Screens and the Central Control for a Smooth Meeting

Accommodating 4 attendee screens at once with synchronized discussions, InstaShare provides the instant and superior interface for both. To manage the meeting, InstaShare has a centrally controlled system which regulates the attendees and mirrored content so that meetings can go on smoothly.



Two-Way Mirroring

Intended to enhance collaboration in business meetings, InstaShare runs two-way mirroring between IFP and mobile devices including smartphones, tablets, and laptops, without the need for video cables interconnecting the devices, no matter it's in-room or remote spaces and the IFP will always have control of itself.



Two-Way Touch Control

InstaShare also supports two-way touch control on Windows and macOS platforms, which means both IFP and client device can control or interact with what is being mirrored. To boost productivity through meetings, annotation is definitely the key InstaShare provides when IFP runs Two-Way Touch Control.



Facilitate Efficient Communication with Friendly Design



Capacitive Touch Technology Direct Bonding

BenQ new DuoBoard Corporate IFPs' fine-tune handwriting experience is enhanced by incorporating the advanced P-cap (Projected Capacitive) touch technology. The P-cap touch enables accurate, precise touch responses on the screen for realistic handwriting. To facilitate team collaboration, it also supports multi-touch capability. In addition, the high-quality glass layer offers great resistance to light, dust, and water, enhancing overall durability.



Reduces the gap between the touch point and the point displayed on screen.

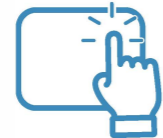

Creates more natural handwriting with a new touch frame that recognizes a smaller radius.



Reduces the pre-touch distance to offer better touch and writing experiences

Hands-Free Control over the IFP with Voice Assistant

BenQ Interactive Flat Panel offers an extra level of flexibility for device control through Voice Assistant. Voice Assistant lets users control the flow of meetings by allowing them to start timers or search the internet from anywhere in the room. Users can easily control the IFP via remote control, further ensuring efficient meetings and effortless collaboration.

Foster a Powerful Collaborative Environment

BenQ IFP ensures businesses can embrace innovation without compromising employee health thanks to smart features that monitor air quality, protect eye health, and reduce the transmission of germs.



Flicker-Free

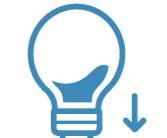

Low Blue Light

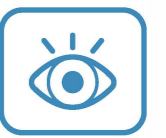

Anti-Glare

Air-Quality Sensor

Poor indoor air quality can decrease efficiency and reduce alertness. BenQ Interactive Flat Panels incorporate an air-quality sensor that monitors CO2 levels and reminds users to adopt measures that can keep CO2 concentrations in check. This handy feature can boost employee focus and ensure that meetings are always efficient and impactful.

Smart Eye-Care Solution

BenQ's Smart Eye-Care Solution uses the Interactive Flat Panel's motion sensor to automatically adjust display settings according to the user's distance from the screen. For a smooth and comfortable viewing experience, BenQ IFPs can automatically activate Flicker-Free and Low Blue Light features as necessary.

Germ-Resistant Screen

The Germ-Resistant Screen is empowered by a multilayer coating of the non-toxic, enduring nano ionic silver agent that kills most germs accumulating on screen surfaces and prevent cross-infection or epidemic in classrooms. The ionic silver's antimicrobial feature remains effective even after thorough cleaning or long periods of use.

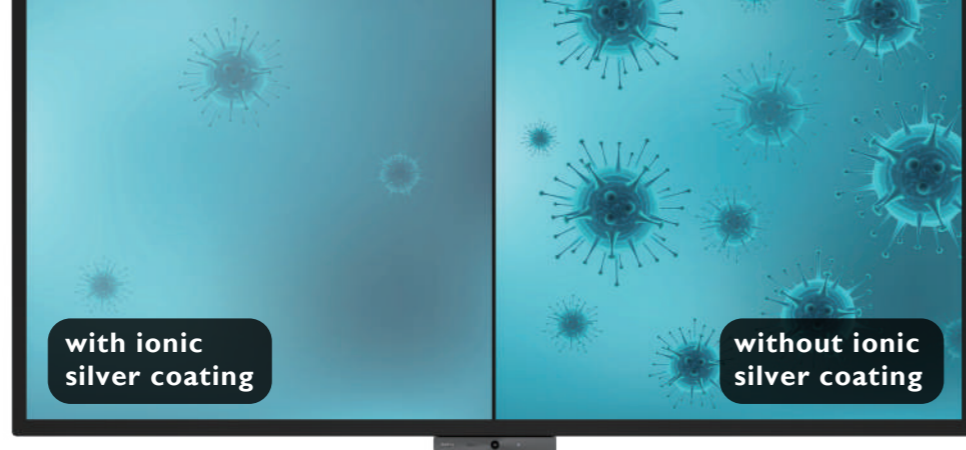

*TUV Test Confirmed

TUV is the world's leading inspection and Verification Company, providing internationally approved testing services to verify product quality and performance. Placing our trust in TUV's best-in-class facilities and world-recognized integrity, we had their experts carefully evaluate the screen's antimicrobial efficacy. Proved by the JIS Z 2801:2010 testing methods, the result shows that BenQ's Germ-Resistant Screen can effectively restrain the growth of Escherichia coli, Staphylococcus aureus and Pseudomonas aeruginosa. To maintain antimicrobial efficacy, please frequently wipe your touch screen with a clean, soft, lint-free cloth moisturized with a neutral detergent.



Dimension(mm)

· CP6501K

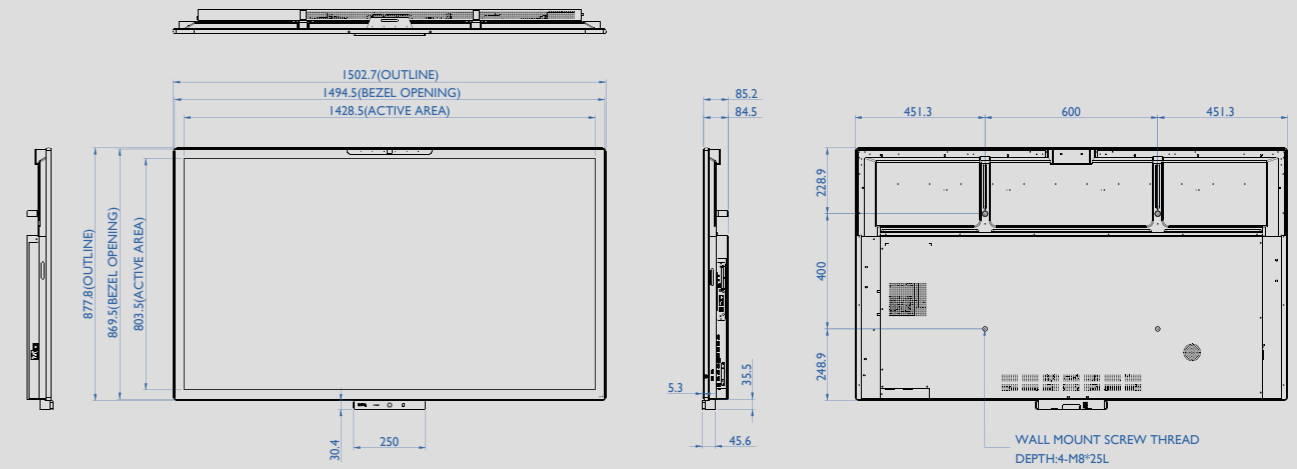

· CP8601K

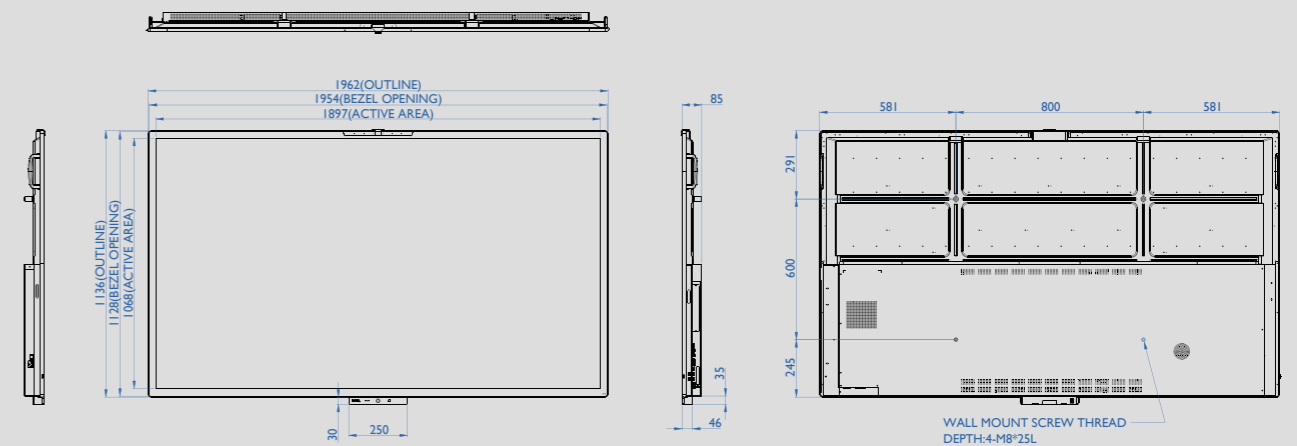

Hassle-Free Display Management and Security

With cloud features, BenQ DMS combined Device Info and Management, Apps Management and OTA (Over-the-Air) Update to provide you an ultimate device management solution for your productivity.



Device Info and Management

Remotely control your displays with DMS Cloud via Internet. It's an effective way to lower TCO and energy consumption for your operation.



Apps Management

Install Android™ apps for a selection of displays through our cloud server. DMS Cloud is designed to save you the hassles of repetitive manual installation work.



OTA (Over-the-Air) Update

Upgrade the latest BenQ firmware for your displays through our OTA Update support and keep them running smoothly at all times.

More Features

· DMS Local

DMS Local is a Device Info and Management software based on windows OS. For users who would like to control your displays remotely via LAN, you can download DMS Local software for your operation.

· MDA (Multiple Display Administrator)

For users who would like to control your displays remotely via RS232, you can download MDA software for your operation.

· McAfee Embedded for Maximum Security

BenQ Interactive Flat Panels are embedded with McAfee for maximum security. McAfee offers device security with Real-time protection, Deep Scan, WebBrowsing Security, and Wi-Fi Security functions. To ensure data security, McAfee provides Privacy Check, APP Access Protection, and Hidden APPs features.

Input/output terminals

- | | |
|----------------|-----------------|
| 1 USB 2.0 | 11 HDMI OUT |
| 2 LAN | 12 USB 3.0 |
| 3 AUDIO OUT | 13 USB 3.0/1.5A |
| 4 RS232 | 14 USB 3.0 |
| 5 SPDIF | 15 TOUCH 1 |
| 6 AUDIO IN/MIC | 16 HDMI IN 1 |
| 7 VGA | 17 HDMI IN 2 |
| 8 Power | 18 HDMI IN 3 |
| 9 USB 2.0 | 19 TOUCH 2 |
| 10 USB 2.0 | 20 USB 2.0 |

